

240GT54/nrg240GT54

Installation Guide

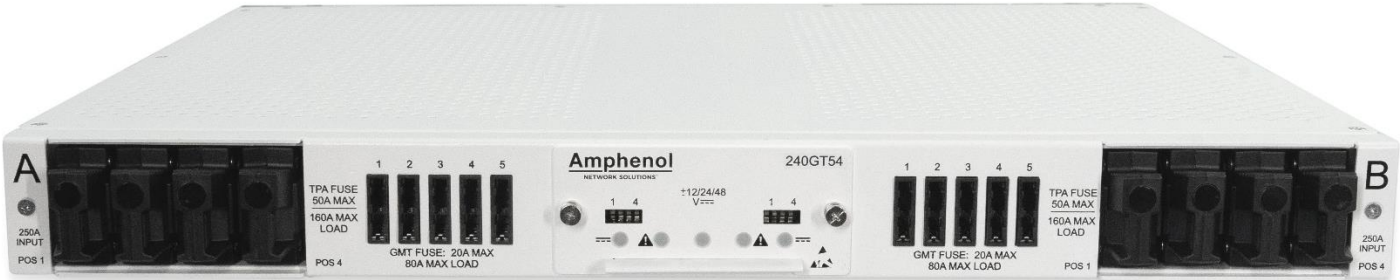

Installation Guide, Part Number 150567 A1

Copyright 2020, Amphenol Network Solutions, All rights reserved.

Amphenol Network Solutions
22425 E. Appleway Ave #11
Liberty Lake, WA 99019

Amphenol Network Solutions assumes no liability from the application or use of these products. Amphenol Network Solutions does not convey any license under its patent rights nor the patent rights of others. This document and the products described herein are subject to change without notice.

About

Amphenol Network Solutions is a global innovative original equipment manufacturer that serves the data and communications markets. We design, manufacture, and distribute products for customers who need an end to end solution for network connectivity, fiber, power distribution and rack management. We collaborate with our customers to deliver product solutions that exceed expectations with innovative designs and world class quality. Amphenol Network Solutions is the industry thought leader on network cable management.



Telect, Inc. has been a market leader in secondary DC power distribution for over 36 years. Through our acquisition by Amphenol and our merger with All Systems Broadband, to become Amphenol Network Solutions, we have continued to deliver reliable, high-quality solutions to power, protect, and monitor today's network servers and equipment. We are proud to be an Amphenol company that will continue to be Powered by Telect.

Technical Support

Email: support@amphenol-ns.com
Phone: 509.926.6000

Table of Contents

Section One: Overview	6
1.1 About this Guide	6
1.2 nrgSMART™	6
1.3 240GT54 Configurations	7
1.4 240GT54 Overview	7
1.5 Specifications.....	10
Section Two: Installation.....	12
2.1 Important Installation Guidelines	12
2.2 Installation Instructions	12
2.2.1 Mounting Brackets	13
2.2.2 Tie Bar Installation and Optional 4 Post Mounting Bracket (-C Versions)	13
2.2.3 Optional Tie Bar Installation (-SC Versions)	14
2.2.4 Rack Mounting.....	15
2.2.5 Grounding.....	16
2.2.6 Input Wiring.....	17
2.2.7 Remove Alarm Cover.....	18
2.2.8 Alarming	18
2.2.9 Installing TPA Fuses	20
2.2.10 Installing GMT Fuses	21
2.2.11 Alarm Terminals.....	21
2.2.12 nrgSMART Connectivity (-CTRL Versions)	22
2.2.13 Output Wiring (Terminal Block Versions)	24
2.2.14 GMT Output Wiring (Connectorized Versions)	25
2.2.15 TPA or Breaker Output Wiring (Connectorized Versions).....	26
2.2.16 Install Rear Cover	28
2.3 TPA Fuse Holder	30
2.3.1 Replacing Fuses	30
2.4 Blanking Cover	30
2.5 Circuit Breaker Puller.....	31
2.5.1 Removing Circuit Breakers	31
2.6 Contact Removal Tool	31
2.7 Tie Bar (-C Versions)	32
2.8 Tie Bar with 4 Post Mounting Brackets (-C Versions).....	32
2.9 Tie Bar (-SC Versions).....	32

2.10 Temperature Probes (nrgSMART Versions).....	33
2.11 nrgNET Pinouts (nrgSMART Versions)	34
2.11.1 nrgNET Pinouts (Integrated Controller)	34
2.12 Parts & Accessories	35
2.12.1 Ordering Information	35
2.12.2 GMT Fuses, TPA Fuses and Circuit Breakers.....	36
2.12.3 Lug Reference Guide	38
Section Three: Drawings	39
3.1 240GT54 Drawings	39
Section Four: Notices (nrgSMART Versions).....	47
4.1 FCC Class A Notice	47
4.2 ICES-003 Class A Notice – Avis NMB-003, Class A	47

List of Figures

Fig. 1-1: 240GT54 Front View.....	7
Fig. 1-2: 240GT54 Rear View	8
Fig. 1-3: 240GT54-SC Front View	8
Fig. 1-4: 240GT54-C Rear View	8
Fig. 2-1: Installing Mounting Brackets	13
Fig. 2-2: Installing -C Tie Bar	13
Fig. 2-3: Installing Optional 4 Post Mounting Brackets.....	14
Fig. 2-4: Installing Optional -SC Tie Bar.....	14
Fig. 2-5: Installing Panel in Rack	15
Fig. 2-6: Grounding Lug Connection	16
Fig. 2-7: Input Lugs.....	17
Fig. 2-8: Removing the Alarm Cover.....	18
Fig. 2-9: DIP Switches	18
Fig. 2-10: 240GT54 LED Status.....	19
Fig. 2-11: Remove Fuse Holder.....	20
Fig. 2-12: Installing TPA Fuse.....	20
Fig. 2-13: nrg240GT54 Alarm Terminals.....	21
Fig. 2-14: CTRL Panel Connectivity Ports	23
Fig. 2-15: Output Lugs.....	24
Fig. 2-16: Insert Crimped Terminals.....	25
Fig. 2-17: Connector Front View	25
Fig. 2-18: Insert Retainer	25
Fig. 2-19: Insert Crimped Terminals.....	26
Fig. 2-20: Connector Front View	26

Fig. 2-21: Insert Retainer	26
Fig. 2-22: Insert Connector	27
Fig. 2-23: Rear Cover (Standard Versions).....	28
Fig. 2-24: Rear Cover (-C Versions)	29
Fig. 2-25: Rear Cover (-SC Versions).....	29
Fig. 2-26: Included TPA Fuse Holder PN: 307492	30
Fig. 2-27: Optional Blanking Cover PN: 150203+03	30
Fig. 2-28: Optional Circuit Breaker Puller PN: 307491	31
Fig. 2-29: Optional Contact Removal Tool PN: 150797.....	31
Fig. 2-30: Tie Bar (Included with -C Versions)	32
Fig. 2-31: Tie Bar with Optional 4 Post Mounting Brackets (-C Version) PN: 307622.....	32
Fig. 2-32: Optional Tie Bar (-SC Versions) PN: 307661	32
Fig. 2-33 Optional nrgTEMP Temperature Probe (nrgSMART Versions) PN: nrgTEMP	33
Fig. 2-34: nrgNET Pinout Connections (Integrated Controller).....	34
Fig. 3-1: Front View (Passive Versions).....	39
Fig. 3-2: Front View (nrgSMART -CTRL Versions)	39
Fig. 3-3: Front View (nrgSMART -SENS Versions).....	39
Fig. 3-4: Side View (Standard and -SC Versions)	39
Fig. 3-5: Side View (-C Versions).....	40
Fig. 3-6: Rear View (240GT54).....	40
Fig. 3-7: Rear View (nrg240GT54-CTRL and nrg240GT54-SENS).....	40
Fig. 3-8: Rear View (240GT54-C).....	40
Fig. 3-9: Rear View (nrg240GT54-CTRL-C and nrg240GT54-SENS-C)	41
Fig. 3-10: Rear View (240GT54-SC).....	41
Fig. 3-11: Rear View (nrg240GT54-CTRL-SC and nrg240GT54-SENS-SC).....	41
Fig. 3-12: Bottom View (Standard Versions).....	42
Fig. 3-13: Bottom View (-C Versions).....	43
Fig. 3-14: Bottom View (-SC Versions)	44
Fig. 3-15: Optional 4 Post Mounting Bracket (-C Versions).....	45
Fig. 3-16: Optional Tie Bar (-SC Versions).....	46

Section One: Overview

1.1 About this Guide

This manual provides a comprehensive overview of and installation guidelines for the 240GT54 family of power distribution panels. While care has been taken to define all necessary information, complete details may not be covered. If you have any questions, contact Amphenol Network Solutions Technical Support at support@amphenol-ns.com or call 1-509-926-6000.

Throughout this guide, select information is highlighted in the form of Notes, Alerts, Cautions, and Warnings. These notifications are prominent, and their importance is indicated as follows:

NOTE: General information to which the user should pay special attention.

ALERT

ALERT! Important information and/or instructions to which the user should adhere.

CAUTION

CAUTION! Indicates a hazardous situation, which could result in minor or moderate injury.

WARNING

WARNING! Indicates a hazardous situation, which could result in death or serious injury.

Amphenol Network Solutions assumes no liability from the application or use of these products. Amphenol Network Solutions does not convey a license under its patent rights, nor the patent rights of others. This document and the products described herein are subject to change without notice.

1.2 nrgSMART™

nrgSMART describes the family of distributed network monitoring and management products, from BDFBs to high-current and low-current secondary panels. nrgSMART allows you to collect performance data on distributed assets and tools to help you efficiently access business critical and actionable information.

Amphenol Network Solutions recognizes the industry need to manage distributed assets more efficiently, get better power performance out of deployed assets, as well as pursue realistic and achievable alternative energy goals. Through nrgSMART, access to data at the equipment level provides the foundation for managing performance of a distributed DC power distribution system.

- **Individual circuit monitoring:** Measure power at the circuit level. This enables powerful trend analysis and insights into equipment performance and enables preventative maintenance processes.
 - High accuracy, 100% passive monitoring, with no calibration required.
 - Collect voltage and current for both feed and output circuit.
 - Collect temperature using optional nrgTEMP probes.
- **Network data collection:** Intelligent interpretation of the collected data, based on equipment data signature (smart alarms), drives relevant business decisions.

1.3 240GT54 Configurations

GMT/TPA Combination Fuse Panel:	Part Number:
240A Dual-Feed, 5/4 Panel, Vertical Inputs, Output Terminal Blocks	240GT54
240A Dual-Feed, 5/4 Panel, Horizontal Inputs, Connectorized Outputs (Connectors purchased separately)	240GT54-C
240A Dual-Feed, 5/4 Panel, Vertical Inputs, Connectorized Outputs (Tie Bar and Connectors purchased separately)	240GT54-SC
nrgSMART Circuit Monitoring, Controller, 240A Dual-Feed, 5/4 Panel, Vertical Inputs, Output Terminal Blocks	nrg240GT54-CTRL
nrgSMART Circuit Monitoring, Sensor, 240A Dual-Feed, 5/4 Panel, Vertical Inputs, Output Terminal Blocks	nrg240GT54-SENS
nrgSMART Circuit Monitoring, Controller, 240A Dual-Feed, 5/4 Panel, Horizontal Inputs, Connectorized Outputs (Connectors purchased separately)	nrg240GT54-CTRL-C
nrgSMART Circuit Monitoring, Sensor, 240A Dual-Feed, 5/4 Panel, Horizontal Inputs, Connectorized Outputs (Connectors purchased separately)	nrg240GT54-SENS-C
nrgSMART Circuit Monitoring, Controller, 240A Dual-Feed, 5/4 Panel, Vertical Inputs, Connectorized Outputs (Tie Bar and Connectors purchased separately)	nrg240GT54-CTRL-SC
nrgSMART Circuit Monitoring, Sensor, 240A Dual-Feed, 5/4 Panel, Vertical Inputs, Connectorized Outputs (Tie Bar and Connectors purchased separately)	nrg240GT54-SENS-SC

1.4 240GT54 Overview

The Amphenol Network Solutions 240GT54 family of 1RU, dual-feed 240A per feed, power distribution panels provide high-capacity, $\pm 48V$, $\pm 24V$, and $\pm 12V$ power protection for secondary power distribution to data and communications equipment. The Amphenol Network Solutions 240GT54 family panels are also ideal for primary distribution in small central offices and at remote sites.



Fig. 1-1: 240GT54 Front View



Fig. 1-2: 240GT54 Rear View



Fig. 1-3: 240GT54-SC Front View



Fig. 1-4: 240GT54-C Rear View

This panel accommodates Cooper Bussmann and Littelfuse GMT fuses and Cooper Bussmann TPA fuses. As an optional accessory, AIRPAX 1U circuit breakers can be used as an alternate to TPA fuses. The panel has positions for 10 GMT fuses and 8 bullet-style, plug-in fuse holders or breakers. These 1RU fuse holders feature an ergonomic front grip for easy removal, sliding top cover to protect the fuse from above, and red alarm plunger to indicate a failed fuse. Circuit breakers are an optional accessory that can be installed with a protective cover to protect against unintended on or off switching. Circuit breaker covers are included with all panels. The panel is UL rated using 20A GMT fuses with a maximum continuous output load of 16A, using 50A TPA fuses with a maximum continuous output load of 40A, and using 60A circuit breakers with a maximum

continuous output load of 48A. GMT, TPA fuses, and breakers are sold separately. See amphenol-ns.com to order GMT fuses, TPA fuses, and breakers.

Sides A and B are electrically isolated including the alarm card, which contains power and fuse status relays with dry, Form-C contacts. The contacts are connected to wire-wrap pins for connecting to external visual/audio alarms. Pins can also mate to a TE Connectivity 3-640428-3 connector. The alarm card also controls the four indicator LEDs on the front panel.

This panel is available with standard terminal block outputs or connectorized outputs. All input, output and alarm terminals are within the panel.

For the standard configurations, the feed inputs are vertical dual stud terminals, and the outputs are staggered terminal blocks to accommodate waterfall cable management. The BATT and RTN inputs accommodate dual-hole lugs and the outputs accommodate single-hole lugs. The input terminals are studs, while the output terminals are screws.

For the -C configurations, the feed inputs are horizontal busbars, and the outputs are connectors. This allows input and output cables to exit straight back from the panel. The BATT and RTN inputs accommodate dual-hole lugs. The input landings have holes with 5/8" to 1" spacing. The outputs accommodate connectors that are easily assembled during installation.

For the -SC configurations, the feed inputs are vertical dual stud terminals, and the outputs are connectors. The input cables can be routed directly from above and the output cables exit straight back from the panel. The BATT and RTN input terminals are studs and accommodate dual-hole lugs. The outputs accommodate connectors that are easily assembled during installation.

The ground terminals can accommodate either dual-hole or single-hole lugs. The ground terminals are bolt connections on the sides of the panel, near the rear, and on the bottom of the panel, near the center rear. Only one ground connection is required.

The nrgSMART panels are now available with an integrated controller, designated with a "CTRL" in the part number. This embeds a primary controller directly into the fuse panel, eliminating the need for a separate external controller. For customers that desire 1-point connectivity to a single controller for multiple panels, nrgSMART Sensor panels can be connected to the Controller (CTRL) panel. These Sensor panels are designated with "SENS" in the part number. The Sensors panel contain all required nrgSMART sensing electronics but do not contain the controller electronics. The nrgSMART electronics of Controller and Sensor panels are powered directly off the A and B feeds, while legacy panels are powered off the primary separate external controller through the nrgNET cable. Since, the CTRL panel does not provide power through the nrgNET cable, legacy panels cannot be connected to it. Sensor panels are capable of being daisy chained with legacy nrgCONTROL-BT external controllers. The nrgCONTROL-BT still requires the use of a service link.

NOTE: Do not connect multiple CTRL panels together.

NOTE: Do not connect a CTRL panel to an nrgCONTROL-BT external controller.

For flexibility, a Sensor panel can be upgraded to include an integrated Controller, and a CTRL panel can be downgraded to a SENS panel. Changes can be made in the field by exchanging a circuit board and front panel. Contact Amphenol Network Solutions for more details.

1.5 Specifications

Inputs:	Specifications:
Voltage range (nominal voltage)	±12VDC, ±24VDC and ±48VDC
Max. input load rating	240A @ 45°C per panel (De-rated to 160A @ 65°C)
Short circuit withstand rating	5000A
Nominal power loss at full load	Less than 45W per side @11,520W full load per side (240A x 48V); 240A @ 45°C per panel
Percentage of full power dissipation at nominal voltage	Less than 0.5%
Max. input interrupt device	125% of panel rating (for 240A rated feeds)
Optional (Standard and -SC versions): Vertical input terminal studs (with Keps nuts and flat washers) for dual-hole compression lugs	Two pairs of 3/8"-16 studs on 1" centers per terminal [max. lug width of 1.15" (29.2 mm)]. Torque nut (using 9/16" or 15 mm socket) to 150 in/lb. (~17 N•m), max.
Optional (-C Versions): Horizontal input terminal landings (with Keps nuts, flat washers, and bolts) for dual-hole compression lugs	Two pairs of 3/8" holes on 5/8"-1" centers per terminal [max. lug width of 1.5" (38.1 mm)]. Torque bolt and nut (using 9/16" or 15 mm sockets) to 150 in/lb. (~17 N•m), max.
Input wire size	2/0 AWG to 350 MCM
Grounding:	Specifications:
Earth GND terminal bolts (with spring washers and flat washers) for dual-hole compression lug	Three sets of 1/4"-20 threaded holes on 5/8" centers. [max. lug width of .50" (12.7 mm)]. Torque bolts (using 7/16" or 12 mm socket) to 50 in/lb. (5.5 N•m), max.
Ground wire size	#14 AWG to #4 AWG
Outputs:	Specifications:
Output fuse	20A GMT fuse 50A TPA fuse 60A circuit breaker
Output load	16A continuous GMT fuse 40A continuous TPA fuse 48A continuous circuit breaker
Minimum short circuit interrupt rating	5000A
Optional (Standard Versions): Terminal blocks, single-hole compression lugs	10, #6-32 screws [max. lug width of .32" (8.1)]. Torque screw to 8 in/lb. (.9 N•m), max. GMT fuse 8, #10-32 screws [max. lug width of .50" (12.7)]. Torque screw to 20 in/lb. (2.3 N•m), max. TPA fuse or circuit breaker
Optional (Standard Versions): Output wire size, single-hole compression lug	#22 AWG to #6 AWG, GMT fuse #14 AWG to #4 AWG, TPA fuse or circuit breaker
Optional (-C and -SC Versions): Connectors (purchased separately)	10, P24 connector plugs, latching, safe touch, GMT fuse 8, P40 connector plugs, latching, safe touch, TPA fuse or circuit breaker
Optional (-C and -SC Versions): Output wire size, connectors	#14 AWG to #10 AWG, GMT fuse #12 AWG to #6 AWG, TPA fuse or circuit breaker
GMT fuses	Cooper Bussmann and Littelfuse
TPA fuses	Cooper Bussmann
Circuit breaker	AIRPAX 1U Series
Alarms:	Specifications:
Alarm relay contacts	2A @ 30 VDC; 0.6A @ 60 VDC
Max. alarm card power rating	@12V: 18mA (0.22W) @24V: 20mA (0.48W); @48V: 30mA (1.44W)
Alarm wire size	#24 AWG, typical (#26 to #20 AWG)
Terminals	Wire wrap or mates with TE Connectivity 3-640428-3

Dimensions:		Specifications:	
240GT54/ nrg240GT54	Height: Depth: Width:	1.75" (44 mm) 13.5" (344 mm) 17.0" (432 mm) without brackets 19" and 23" brackets included with panel	
240GT54-C/nrg240GT54-C	Height: Depth: Width:	1.75" (44 mm) 18.7" (475 mm) without tie bar 21.9" (557 mm) with tie bar 17.0" (432 mm) without brackets 19" and 23" brackets included with panel Tie bar included with panel Cable-end connectors not included with panel	
240GT54-SC/nrg240GT54-SC	Height: Depth: Width:	1.75" (44 mm) 13.5" (344 mm) without tie bar 17.0" (432mm) with tie bar 17.0" (432 mm) without brackets 19" and 23" brackets included with panel Tie bar and cable-end connectors not included with panel	
Compliance:		Specifications:	
UL		Listed	
NEBS		Level 3	
Voltage Sensor (nrgSMART model only):		Specifications:	
Sensor accuracy		-19.99 to +19.99V: ± 0.3V -20V to -60V: ± 0.1V +20V to +60V: ± 0.1V	
Voltage measurement range		-60 to +60 VDC	
NOTE:			
<ul style="list-style-type: none"> • Voltage measurement may be slightly different than at input terminal blocks due to the voltage drop within the panel. • Sensors are factory calibrated and do not require user adjustment. 			
Current Sensor (nrgSMART model only):		Specifications:	
Precision / accuracy		±5% precision, ±0.25A accuracy Example: 40A current, will measure 40A ± (40A*5%) ± 0.25A = 40A ± 2.0A ± 0.25A = 37.75A to 42.25A	
Communication (nrgSMART model only):		Specifications:	
nrgOS minimum required version		nrgOS 4.1.0	
nrgNET communication protocol		Proprietary serial protocol used to communicate between panels and controller	
nrgNET connector		Removable 5-pin connector with screw down terminals	
nrgNET connector functions		nrgNET IN from the Controller or upstream nrgSMART panel, nrgNET OUT to downstream nrgSMART panel	

Section Two: Installation

2.1 Important Installation Guidelines

- **Elevated Operating Ambient Temperature:** If installed in a closed or multi-unit rack assembly, the operating ambient temperature of the rack environment may be greater than room ambient. Consider installing the equipment in an environment compatible with the maximum ambient temperature (T_{ma}) specified by the manufacturer.
- **Reduced Air Flow:** Maintain the amount of air flow required for safe operation when installing the equipment in a rack.
- **Mechanical Loading:** Ensure mechanical loading is even to prevent hazardous conditions.
- **Circuit Overloading:** Overloading circuits may affect your overcurrent protection and supply wiring. Use equipment nameplate ratings.
- **Reliable Earthing:** Maintain reliable earthing of rack-mounted equipment. Pay attention to supply connections other than direct connections to the branch circuit.
- **Disconnect Device:** Incorporate a readily accessible disconnect device in the building installation wiring.

2.2 Installation Instructions

ALERT

ALERT! Only qualified technicians may install and maintain this product. Verify all connections meet requirements specified in local electric codes or operating company guidelines before supplying power. Protect this equipment with a breaker sufficient to interrupt power levels specified.

ALERT! Verify all connections meet requirements specified in local electric codes or operating company guidelines before supplying power. Unit shall be protected by a listed circuit breaker or branch-rated fuse rated minimum 125% of panel rating (for 240A rated feeds).

ALERT! Install this product in locations accessible only to qualified personnel.

Please read these instructions carefully before beginning installation. If assistance is required, call Amphenol Network Solutions Technical Support at 1-509-926-6000 or email us at support@amphenol-ns.com.

When you receive the equipment, carefully unpack it and compare it to the packaging list. Please report any defective or missing parts to Amphenol Network Solutions Quality at quality@amphenol-ns.com or call 1-509-926-6000.

Amphenol Network Solutions is not liable for transit damage. If the product is damaged, please report it to the carrier and contact Amphenol Network Solutions Quality.

NOTE: For service or warranty information, please visit amphenol-ns.com and click on the support tab, email Amphenol Network Solutions at getinfo@amphenol-ns.com or call us at 1-509-926-6000.

NOTE: The 240GT54 family is suitable for installation as part of a Common Bonding Network (CBN) for installation in Network Telecommunication Facilities and OSP.

NOTE: The 240GT54 family is DC-I and can be grounded in both CBN and IBN networks. All feeds have isolated returns and the chassis grounds are isolated from all returns. The 240GT54 family is suitable for installation in Network Telecommunication Facilities and in locations where the NEC applies.

240GT54/nrg240GT54

2.2.1 Mounting Brackets

1. The mounting brackets can be installed in 6 positions, from flush to 5 inch offset in 1 inch increments. Use included hardware to install the mounting brackets. Both 19" and 23" mounting brackets are included.
2. Tighten screws to 20 in/lb. (2.23 N•m).

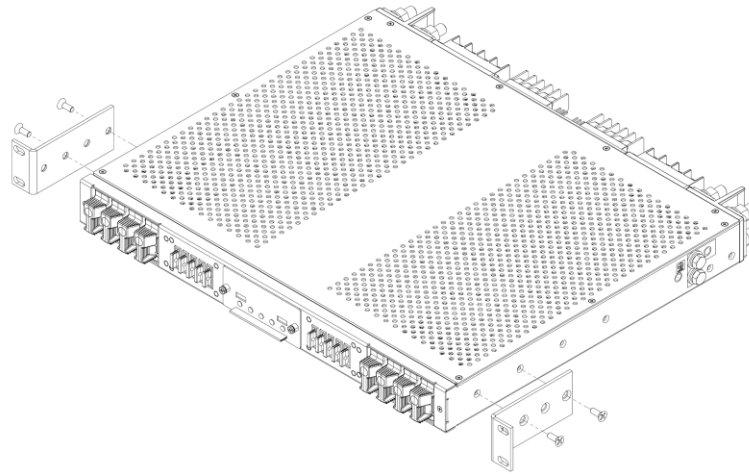

Fig. 2-1: Installing Mounting Brackets

2.2.2 Tie Bar Installation and Optional 4 Post Mounting Bracket (-C Versions)

3. Use included undercut hardware to install tie bar. Standard tie bar is included in -C connectorized panels.
4. Tighten screws to 20 in/lb. (2.3 N•m).

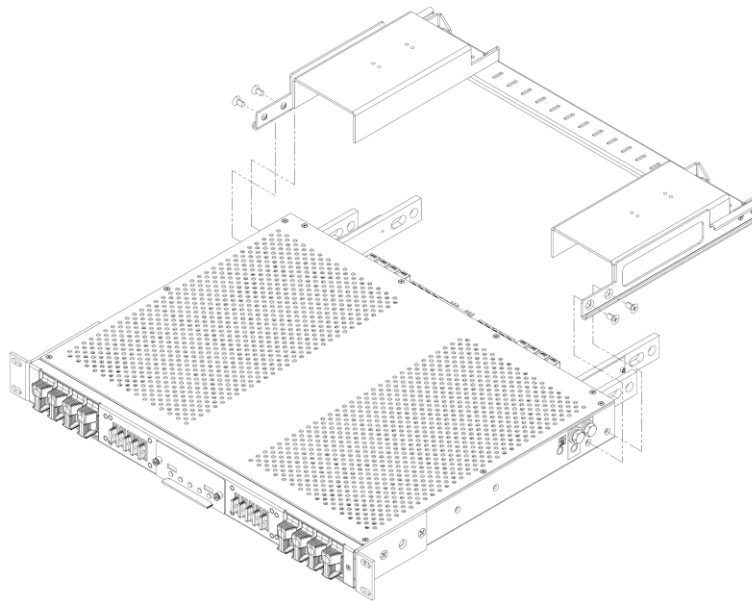

Fig. 2-2: Installing -C Tie Bar

5. 4 post mounting brackets are an optional accessory for -C connectorized panels and purchased separately. Slide 4 post mounting brackets into the tie bar. This step can also be done after the front of the panel is mounted in the rack.

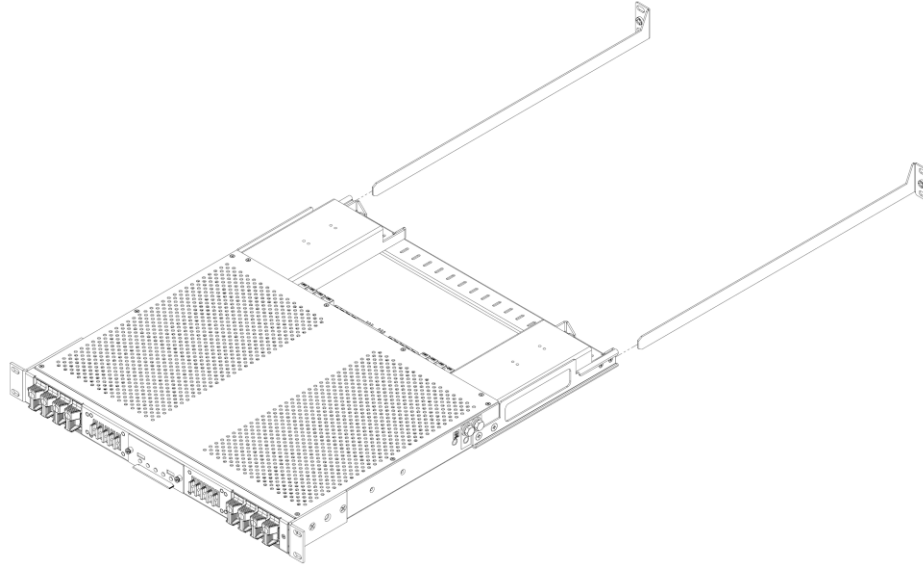

Fig. 2-3: Installing Optional 4 Post Mounting Brackets

2.2.3 Optional Tie Bar Installation (-SC Versions)

6. Tie bar is an optional accessory for -SC connectorized panels and is purchased separately. Use hardware included in accessory kit to install tie bar.
7. Tighten screws to 20 in/lb. (2.3 N•m).

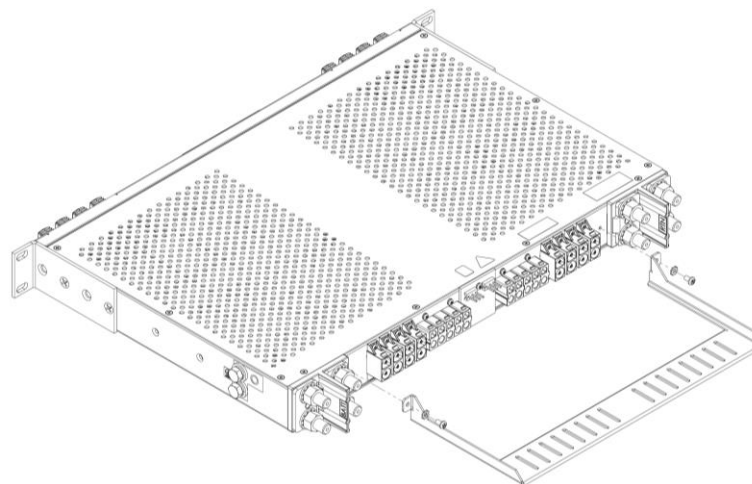

Fig. 2-4: Installing Optional -SC Tie Bar

2.2.4 Rack Mounting

8. Locate an unused rack position and mount the panel using two sets of fasteners per side, as shown in Fig. 2-5. Mount the panel as high as possible on the rack. Use a seismic rack for best rigidity.
9. Tighten screws to 35 in/lb. (3.9 N•m).

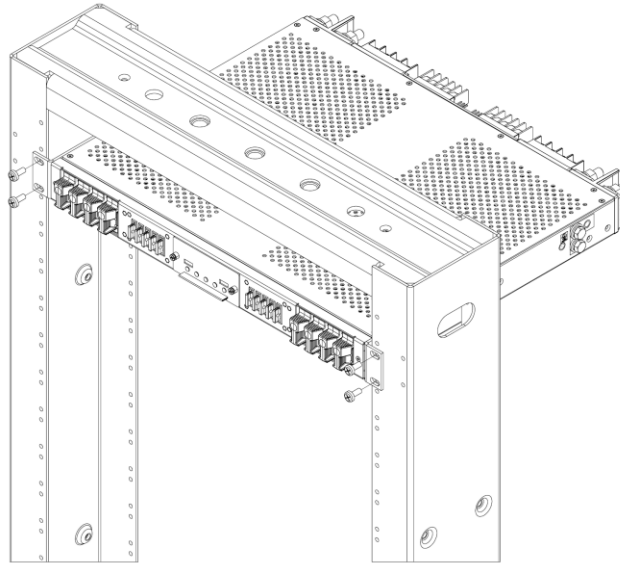

Fig. 2-5: Installing Panel in Rack

2.2.5 Grounding



WARNING

WARNING! Failure to properly ground this equipment can create hazardous conditions to installation personnel and to the equipment.



ALERT

ALERT! Only use components and crimping tools approved by agencies or certifying bodies recognized in your country or region such as Underwriter's Laboratories (UL), TUV, etc.

10. Use an approved crimping tool to attach an approved, dual-hole compression lug onto suitable grounding wire. (Size of ground depends on input interruption device.)
11. If required, lightly coat antioxidant on lug and grounding surface on the side or bottom of the panel. Connect the lug using $\frac{1}{4}$ -20 bolts, split washers and flat washers provided, as shown in Fig. 2-6.
12. Tighten the bolt to 50 in/lb. (5.6 N•m).

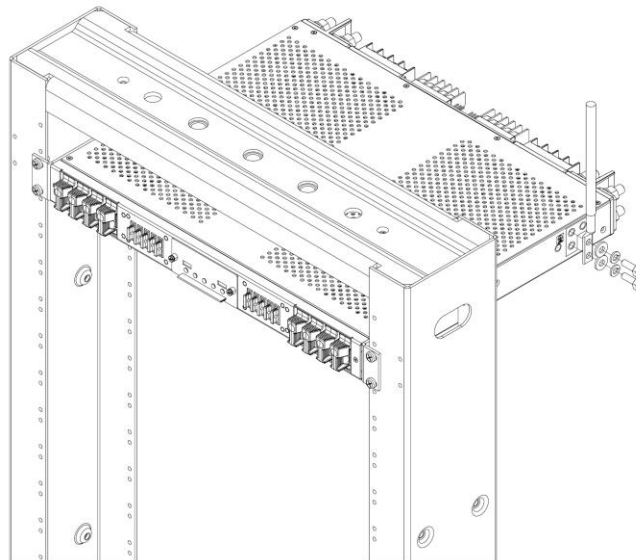

Fig. 2-6: Grounding Lug Connection

2.2.6 Input Wiring

WARNING

WARNING! Before connecting input power cables, make sure input power to the panel is turned off.

13. Make sure input power is off before connecting the panel's input cables to the PDU or battery.
14. For input wiring, crimp dual-hole compression lugs onto 2/0 AWG to 350 MCM copper wires. The choice of input wiring depends on the following criteria:
 - Input interrupt device rating affects the size of input wiring.
 - Ambient operating temperature affects the type of input wire insulation. For further information, consult the National Electrical Code (NEC).
15. Insulate the lug barrels with UL94 V-0 rated heat-shrink tubing.
16. Clean terminals and lugs with a non-abrasive, non-metallic pad.
17. If required, lightly coat antioxidant on lugs and input BATT and RTN terminals and then connect lugs to input terminals, as shown in Fig. 2-6.
18. Tighten nut to 150 in/lb. (~17 N•m), max.

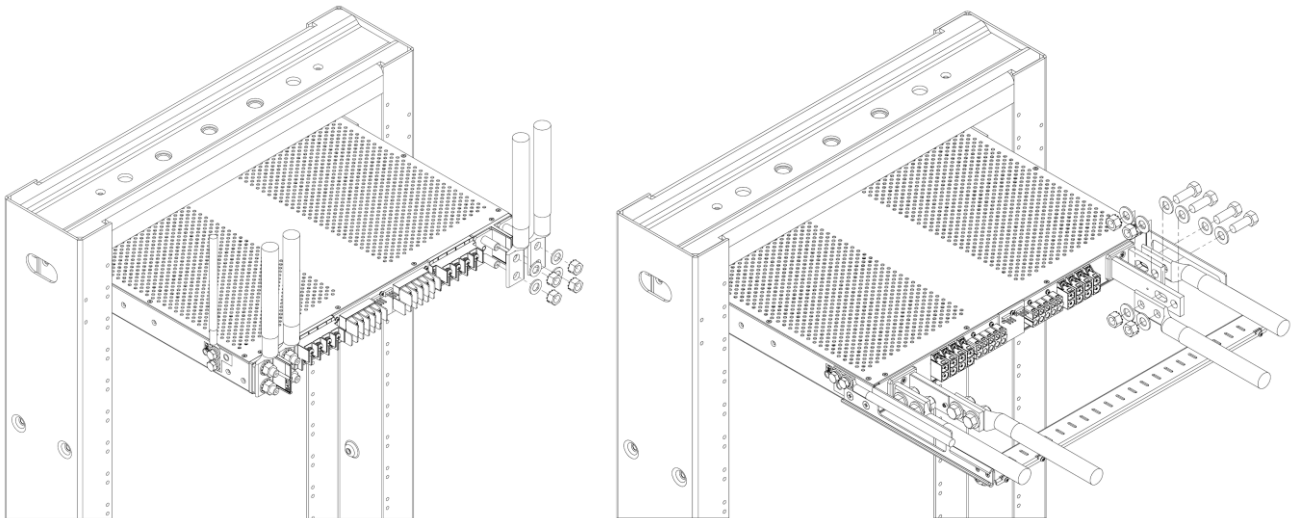

Fig. 2-7: Input Lugs

2.2.7 Remove Alarm Cover

19. Remove alarm cover using Phillips screwdriver, as shown in Fig. 2-8. Once the front cover has been taken off the panel, remove and discard the small pink packaging foam piece inside the front cover.

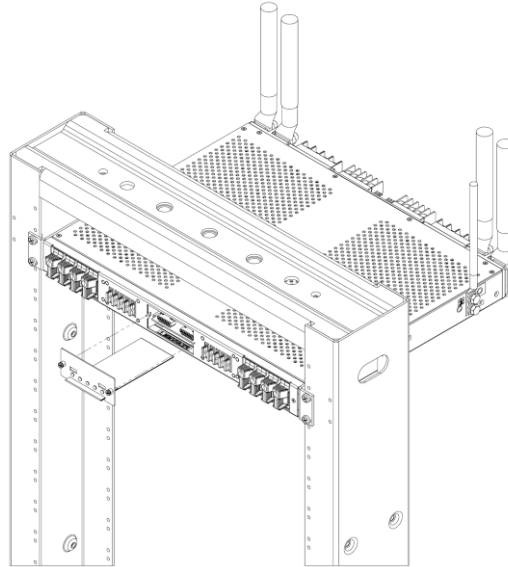

Fig. 2-8: Removing the Alarm Cover

2.2.8 Alarming

20. When installing TPA fuses or breakers into the fuse holders, turn on the corresponding DIP switch by flipping the switch on (down position). This will turn on the alarming function for the TPA fuses or breakers that are installed. If a fuse or breaker is not installed, that corresponding DIP switch needs to be turned off (up position) to prevent false alarming. For side A, dip switches are numbered 1-4 and correspond to the matching fuse holder position. For side B the dip switches are numbered 5-8, where dip switch 5 corresponds to fuse position 1 and dip switch 8 corresponds to fuse of breaker position 4.

NOTE: Side A dip switches 5-8, and side B dip switches 1-4, are not used and should remain in the off (up) position to prevent false alarming.

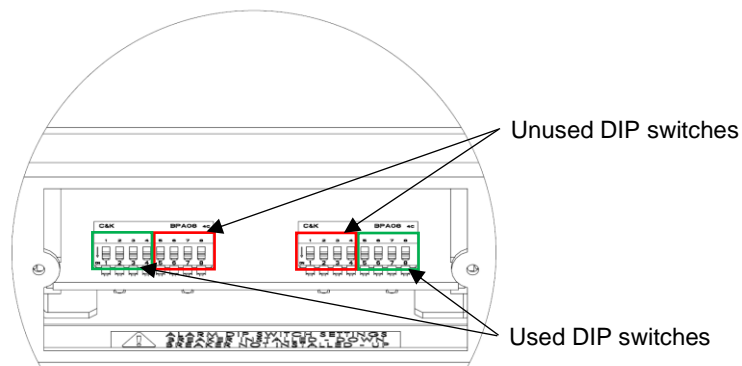

Fig. 2-9: DIP Switches

NOTE: For nrgSMART panel only. When removing or installing new GMT fuses, TPA fuses, or circuit breakers, ensure the changes are updated in the nrgSMART configuration wizard.

21. With all the GMT positions uninstalled, TPA fuse holders empty, or breakers off enable the breaker at the primary distribution unit or battery, 125% of panel rating (for 240A rated feeds) to turn on Feed A to Side A of the panel. Check voltage and polarity at input connectors of the panel.

Verify the following:

- A PWR LED on the front of panel turns green
- A ALM LED on the front of panel turns red
- B PWR LED remains off
- B ALM LED remains off

22. With A PWR LED green (normal operation) and A ALM LED red (alarm state) — but with B PWR LED and B ALM LED off — test ALM relay and contact alarm terminals:

- Expect an open circuit ($\infty\Omega$) between terminals C and NC
- Expect continuity (0Ω) between terminals C and NO

23. With no output wires connected or with the output loads (devices fed by this panel) disabled, install GMT fuses and TPA fuses into the fuse holders or turn on breakers, see section 2.2.9 and 2.2.10.

Verify the following:

- A PWR LED on the front of panel turns green
- A ALM LED turns off
- B PWR LED remains off
- B ALM LED remains off

24. If A ALM LED is red, verify that all of the DIP switches for all empty TPA fuse or circuit breaker positions are up (OFF).

25. With A PWR LED green (normal operation) and A ALM LED off (normal state) —but with B PWR LED and B ALM LED off — test A ALM relay and contact terminals:

- Expect continuity (0Ω) between terminals C and NC
- Expect an open circuit ($\infty\Omega$) between terminals C and NO

26. Repeat steps 21-25 to power up side B. A PWR and B PWR LEDs must both be green.

27. Reinstall the cover to the front of the panel using the thumb screws or a Phillips screwdriver.

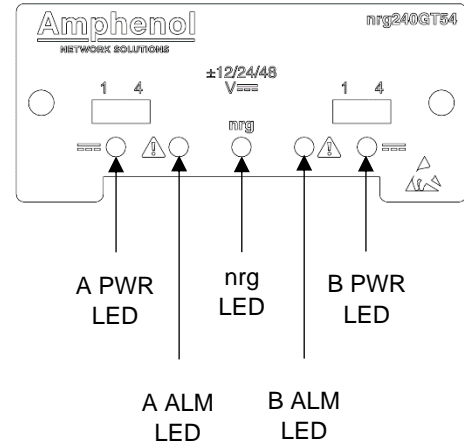

Fig. 2-10: 240GT54 LED Status

2.2.9 Installing TPA Fuses

28. Remove fuse holder from panel.

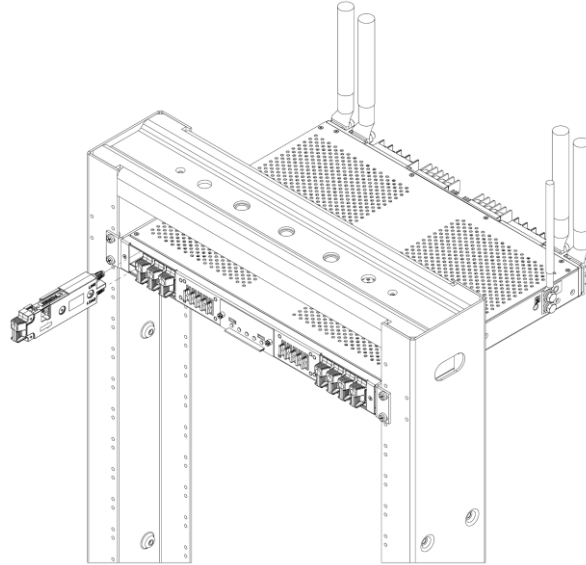

Fig. 2-11: Remove Fuse Holder

29. Open fuse holder cover by sliding it back. Install fuse into fuse holder. Ensure the fuse is inserted in the proper orientation. Close fuse holder cover.

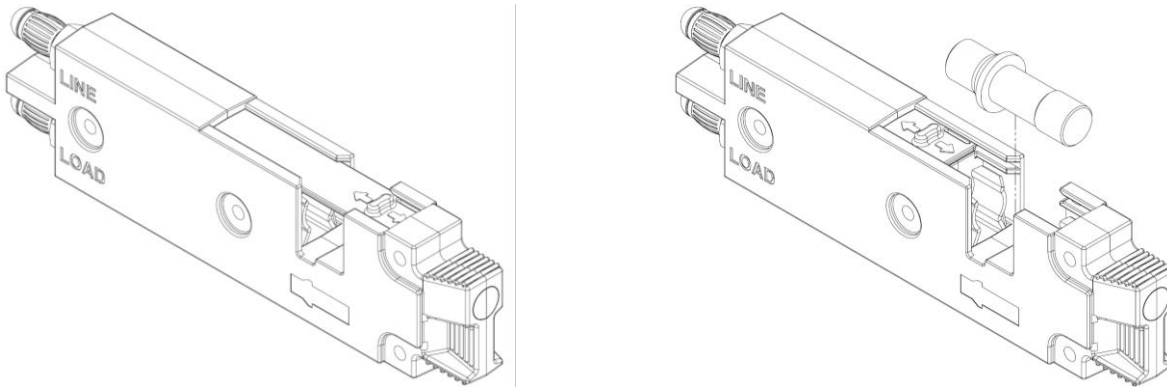

Fig. 2-12: Installing TPA Fuse

NOTE: Ensure the corresponding DIP switches for installed fuses are in the down (ON) position and that the DIP switches for the corresponding empty positions are in the up (OFF) position.

30. Install fuse holders in the desired circuit. Ensure “Line” is on top.

2.2.10 Installing GMT Fuses

! ALERT

ALERT! GMT fuses have a small inherent electrical resistance resulting in a small inherent power loss. For this reason, the GMT fuse manufacturer recommends that the load for GMT fuses up to and including 7.5A not exceed 80% of the fuse rating and that the load for GMT fuse sizes between 10A and 20A not exceed 70% of the fuse rating. For example, the load for a 15A GMT fuse should not exceed 10.5A (15A x.70 = 10.5A).

31. Install GMT fuse into panel in appropriate positions.
32. For any positions without a GMT fuse, a dummy fuse must be inserted in its place. If a fuse is installed at a later time, remove the dummy fuse and retain for future use.
33. To remove a dummy fuse, use a small pair of needle nosed pliers or equivalent to pull it out of position.

2.2.11 Alarm Terminals

34. The alarm terminals, nrgTEMP connectors, and nrgNET connectors are located in the rear center of the panel. Refer to Fig. 2-13.

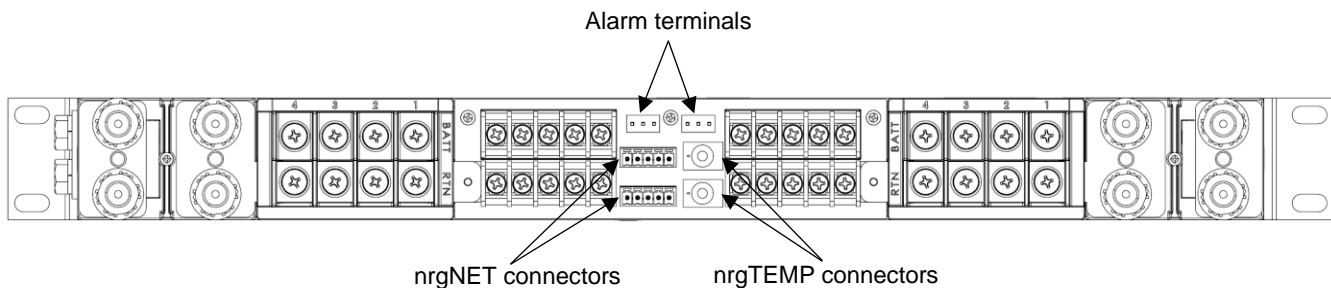

Fig. 2-13: nrg240GT54 Alarm Terminals

35. For the alarm terminals, it is possible to use a short, manual wire-wrap tool to install alarm wiring after securing the panel to the rack. As an alternate to wire wrap, TE Connectivity insulation displacement connector, part number 3-640428-3, can be used to connect to the alarm terminals.
36. Two nrgTEMP connectors are available on the panel and accept the optional nrgTEMP probes.
37. The Amphenol Network Solutions proprietary communication link, nrgNET, connects nrgSMART controller panels and nrgSMART panels. Legacy nrgSMART panels used a single cable with four conductors to provide power and data communication. CTRL and SENS panels use the same four conductor cable to provide data communication, with two of the conductors being unused.
38. For nrgNET wiring used to daisy chain the controller panel to the attached nrgSMART panels do the following:
 - a. Strip $\frac{3}{8}$ -in. of insulation away from the four conductor wires in the nrgNET cable
 - b. Insert the wires into the connector and tighten the screws to hold the wires in place making sure to connect the proper wire to the pins as illustrated in nrgNET Pin Outs Table 2.9.1 and in Fig. 2-34.
 - c. Insert the connector into the open end of the controller panel.

2.2.12 nrgSMART Connectivity (-CTRL Versions)

39. The CTRL panels utilize the LAN port location on the front of the unit to connect the controller to the data storage location. The controller can be operated in the following modes simultaneously:

Local Only Mode:

- The controller will collect data from all panel sensors that are connected to it over the nrgNET interface.
- No SNMP traps or data is sent for monitoring.
- The instantaneous sensor data can be viewed from the front of the controller's LCD screen for all attached monitoring panels.

SNMP Mode:

- The LAN port must be connected and configured to operate on the same subnet as the customer defined SNMP/ NMS server address.
- The nrgSMART MIB table is available for download at the following URL:
<https://amphenol-ns.com/Product/nrgsmart-controller>
- SNMP traps can be set-up for current threshold crossings, breaker trips or blown fuses, voltage threshold crossings and temperature threshold crossings.
- Sensor data and configuration data can be polled by issuing commands from the NMS.
- The NMS will have to manage and store all collected data.

40. The CTRL panel uses a static IP address of 192.168.1.1 with a subnet mask of 255.255.255.0. You will need to set up your PC or server to an address on the same subnet as the CTRL panel. To do this, follow the steps below.

- a. Connect a CAT5 cable to the front panel LAN connector of the CTRL panel.
- b. Go into Network Settings from either the CTRL Panel or the Network icon in the bottom right corner of the task bar on your PC. Note: There will be different paths to get to these settings based on your operating system.
- c. Double-click Ethernet or LAN connection.
- d. Select Internet Protocol Version 4 (TCP/IPv4)
- e. Change your setting from Obtain an IP Address Automatically to Use the Following IP Address in the subnet range of 192.168.1.2 - 192.168.1.254 subnet mask of 255.255.255.0; no gateway or DNS needed.
- f. Hit OK on the next two screens to complete the change.
- g. Open the CTRL panel via a browser by its IP address of 192.168.1.1 Note: Chrome is the recommended browser. Other supported browsers include Firefox.
- h. The Configuration Wizard will be displayed. RJ-45 LAN port

41. The MGMT Port is not enabled and will be updated in a future firmware release.

42. For information on connecting and configuring your nrgSMART panels, please refer to nrgSMART Configuration Guide.

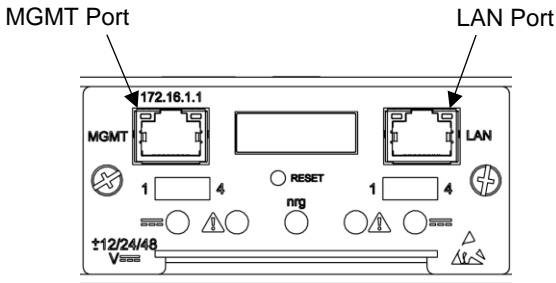

Fig. 2-14: CTRL Panel Connectivity Ports

2.2.13 Output Wiring (Terminal Block Versions)

⚠ WARNING

WARNING! Before connecting output power cables, make sure input power to the panel is turned off.

43. For GMT output wiring, crimp single-hole lugs onto one end of #22 to #6 AWG copper wires, as required by NEC. For TPA or breaker output wiring crimp single-hole lugs onto one end of #14 to #4 AWG copper wires as required by NEC. (Work with one output wire at a time.)
44. Insulate lug barrels with UL94 V-0 rated heat-shrink tubing.
45. Clean the panel terminal and lugs with a non-abrasive, non-metallic pad.
46. If required, lightly coat antioxidant on lugs and output BATT and RTN terminals and then connect lugs to terminals, as shown in Fig. 2-15. (NEC specifies only one lug and load at each output terminal.)

⚠ ALERT

ALERT! Do not exceed torque rating. The output terminals are low electrical resistance, free floating terminals. Note that the top output terminals may rotate slightly within the rear of the panel. This is normal.

47. Tighten screws for GMT positions to no more than 8 in/lb. (2.3 N•m), max. Then connect other end of output wire to load. Tighten screws for TPA or breaker positions to no more than 20 in/lb. (2.3 N•m), max. Then connect other end of output wire to load.

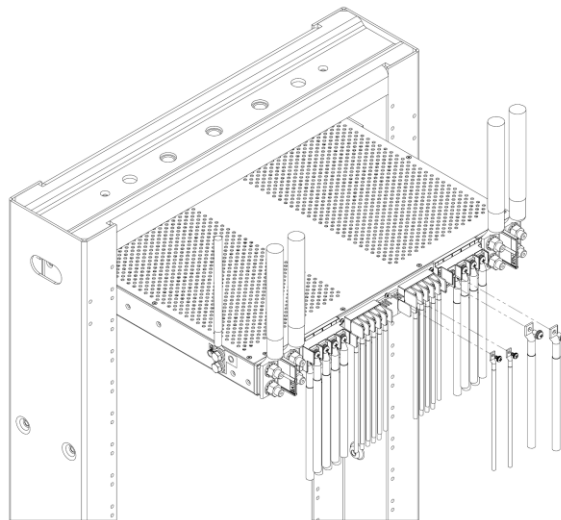

Fig. 2-15: Output Lugs

48. With the output loads (devices fed by this panel) disabled, re-enable breakers at primary distribution unit or battery.
49. If applicable, check voltage and polarity *at loads*.
50. Record circuit assignments in accordance with operating company procedures and guidelines.
51. Enable equipment loads one at a time to verify proper operation of loads.

2.2.14 GMT Output Wiring (Connectorized Versions)

WARNING

WARNING! Before connecting output power cables, make sure input power to the panel is turned off.

52. P24 output connectors are available in two sizes, #14-12 AWG and #12-10 AWG. Depending on the output connector, crimp terminals onto one end of #14 to #10 AWG copper wires using Daniels M300BT crimp tool or Burndy Y8MRB-1 crimp tool. (Work with one output wire at a time.)

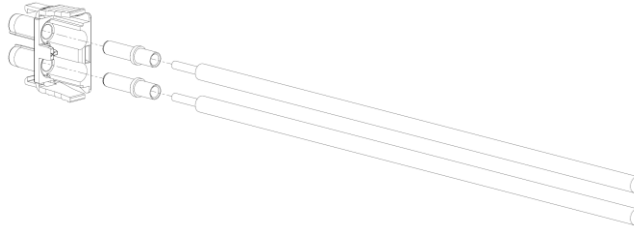

Fig. 2-16: Insert Crimped Terminals

53. Insert terminals into plug housing as shown in Fig. 2-16 and Fig. 2-17. The battery terminal goes in the position on the connector with 2 locator tabs and is marked “2”. The return terminal goes in the position on the connector with 1 locator tab and is marked “1”.

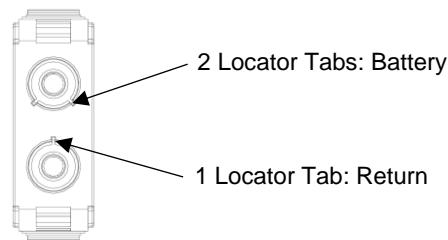

Fig. 2-17: Connector Front View

54. Insert retainer into plug housing as shown in Fig. 2-18.

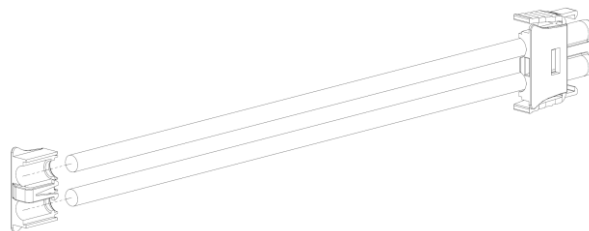

Fig. 2-18: Insert Retainer

Note: If cables were placed in incorrect position, use a small pair of needle nose pliers or equivalent to squeeze the retainer latch together. With latches released, grip the plug housing and pull on cables to remove retainer.

2.2.15 TPA or Breaker Output Wiring (Connectorized Versions)

WARNING

WARNING! Before connecting output power cables, make sure input power to the panel is turned off.

55. P40 output connectors are available in two sizes, #12-10 AWG and #8-6 AWG. Depending on the Output connector, crimp terminals onto one end of #12 to #6 AWG copper wires using Daniels M300BT crimp tool or Burndy Y122CMR crimp tool. (Work with one output wire at a time.)

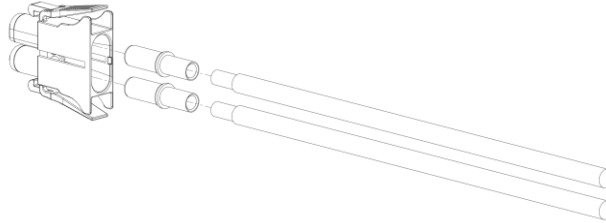

Fig. 2-19: Insert Crimped Terminals

56. Insert terminals into plug housing as shown in Fig. 2-19 and Fig. 2-20. The battery terminal goes in the “D” shaped position on the connector. The return terminal goes in the round housing position.

NOTE: A good way to remember is “Round = Return”.

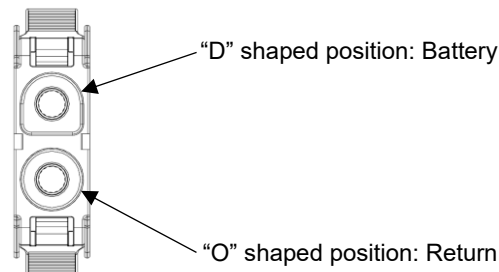

Fig. 2-20: Connector Front View

57. Insert retainer into plug housing as shown in Fig. 2-21 Ensure the retainer flanges are inserted into the connector first.

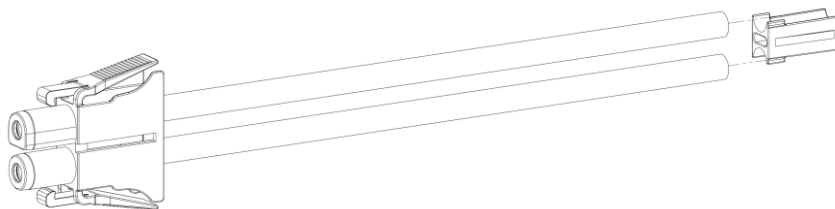

Fig. 2-21: Insert Retainer

Note: If cables were placed in incorrect position, use Contact Removal Tool, PN 150797, to disassemble the connector. Insert the removal tool between the housing and the retainer. With removal tool inserted, grip the plug housing and simultaneously pull on cables and removal tool to remove parts from the housing.



CAUTION

CAUTION! The removal tool is sharp. Care should be taken when disassembling the connector.

58. Insert the connector into the panel. Ensure that the plug latches into place. Then connect other end of output wire to load.

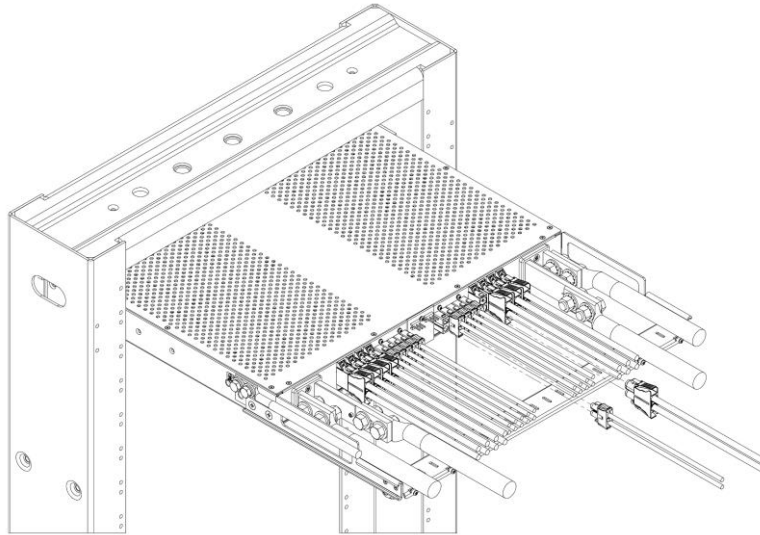

Fig. 2-22: Insert Connector

- 59. With the output loads (devices fed by this panel) disabled, re-enable breakers at primary distribution unit or battery.
- 60. If applicable, check voltage and polarity *at loads*.
- 61. Record circuit assignments in accordance with operating company procedures and guidelines.
- 62. Enable equipment loads one at a time to verify proper operation of loads.

2.2.16 Install Rear Cover



WARNING

WARNING! The rear cover protects the rear of the panel while energized. Not installing the rear cover may create an electrical hazard.

63. Install rear plastic cover using provided hardware, as shown in Fig. 2-23, Fig. 2-24, and Fig. 2-25.

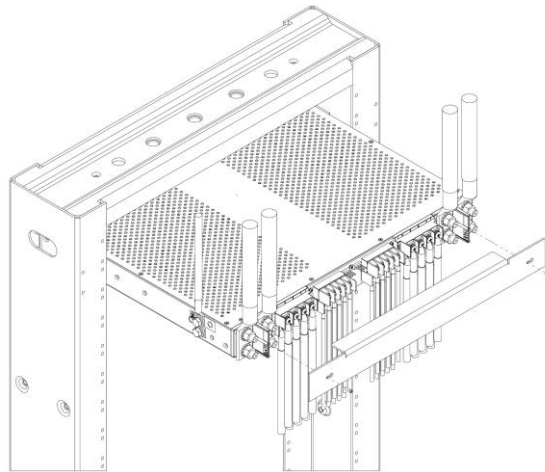

Fig. 2-23: Rear Cover (Standard Versions)

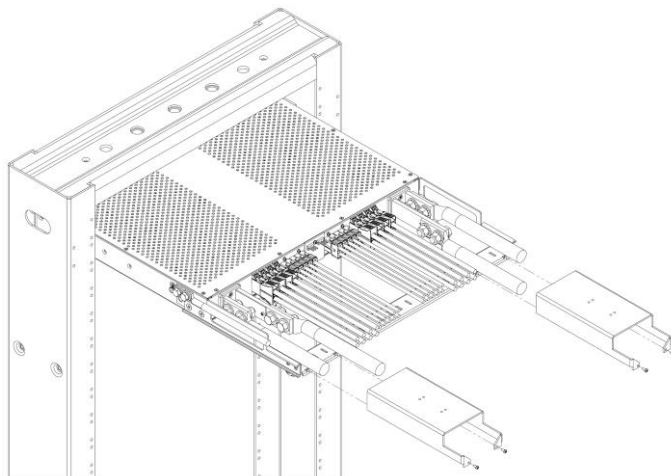

Fig. 2-24: Rear Cover (-C Versions)

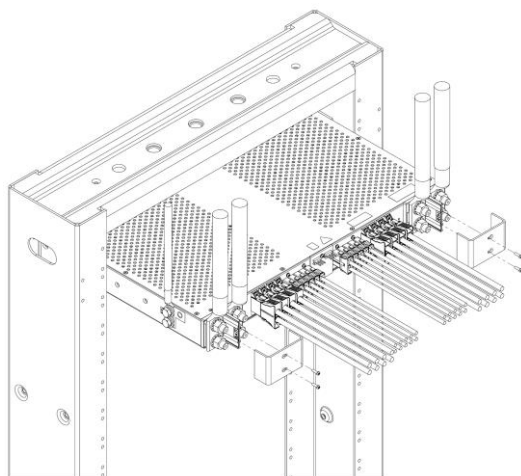

Fig. 2-25: Rear Cover (-SC Versions)

2.3 TPA Fuse Holder

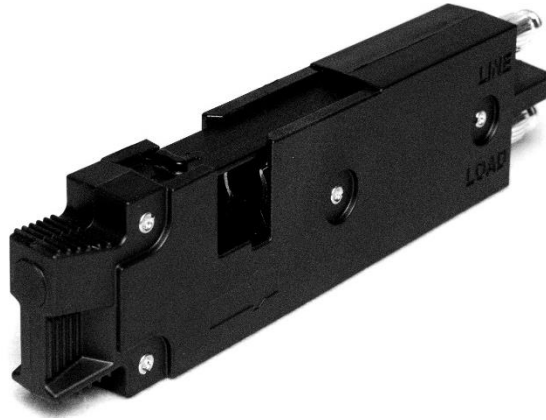

Fig. 2-26: Included TPA Fuse Holder PN: 307492

2.3.1 Replacing Fuses



WARNING

WARNING! Ensure load is powered off before removing fuse holder from panel.

1. Grip the front of the fuse holder and pull straight back until it is removed from the panel.
2. Open the fuse holder cover by sliding the cover back. Use a small screwdriver or equivalent to pry the fuse from the fuse holder. Ensure the new fuse is inserted in the proper orientation. Close the fuse holder cover. If the alarm plunger was pushed forward from a blown fuse, push it back into place.
3. If the old fuse is not being replaced with a new fuse, reinsert the empty fuse holder or blanking cover and ensure the corresponding dip switch is switched to the off (up) position.

2.4 Blanking Cover

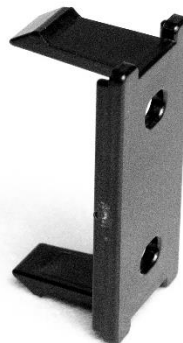

Fig. 2-27: Optional Blanking Cover PN: 150203+03

2.5 Circuit Breaker Puller



Fig. 2-28: Optional Circuit Breaker Puller PN: 307491

2.5.1 Removing Circuit Breakers

⚠ WARNING

WARNING! Ensure circuit breaker is in off position before removing from panel.

1. If the breaker has a cover installed, remove it by using a Phillips screwdriver to remove mounting screws.
2. Thread a circuit breaker puller into the captive threaded holes on the front of the circuit breaker.
3. Pull the breaker puller straight back until the circuit breaker is removed from the panel.
4. If the breaker that was removed is not being replaced with a new breaker, ensure the corresponding dip switch is switch to the off (up) position.
5. If a new breaker is replacing the old breaker, an optional cover can be installed using a Phillips screwdriver to install the mounting screws.

2.6 Contact Removal Tool



Fig. 2-29: Optional Contact Removal Tool PN: 150797

2.7 Tie Bar (-C Versions)

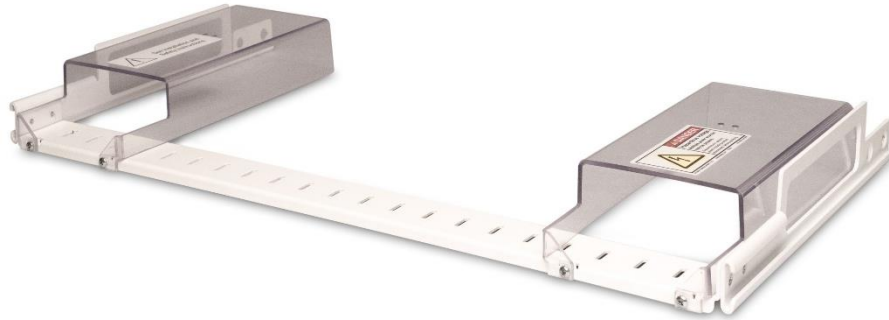

Fig. 2-30: Tie Bar (Included with -C Versions)

2.8 Tie Bar with 4 Post Mounting Brackets (-C Versions)



Fig. 2-31: Tie Bar with Optional 4 Post Mounting Brackets (-C Version) PN: 307622

2.9 Tie Bar (-SC Versions)

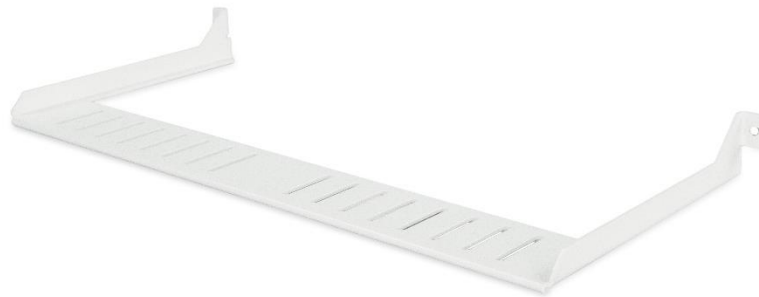

Fig. 2-32: Optional Tie Bar (-SC Versions) PN: 307661

2.10 Temperature Probes (nrgSMART Versions)



Fig. 2-33 Optional nrgTEMP Temperature Probe (nrgSMART Versions) PN: nrgTEMP

Two temperature probe ports are available on the back of the nrgSMART versions of panels. Each port can accept the optional nrgTEMP probe. See Fig. 2-13.

2.11 nrgNET Pinouts (nrgSMART Versions)

2.11.1 nrgNET Pinouts (Integrated Controller)

Pin Number	Label	Wire
Pin 1	COM +	White (22 AWG)
Pin 2	COM -	Blue (22 AWG)
Pin 3	S	Drain Wire (24 AWG)
Pin 4	PWR +	Black (18 AWG)
Pin 5	PWER -	Red (18 AWG)

CTRL Panel



Pin 1
Pin 2
Pin 3
Pin 4
Pin 5

SENS Panel



Pin 1
Pin 2
Pin 3
Pin 4
Pin 5

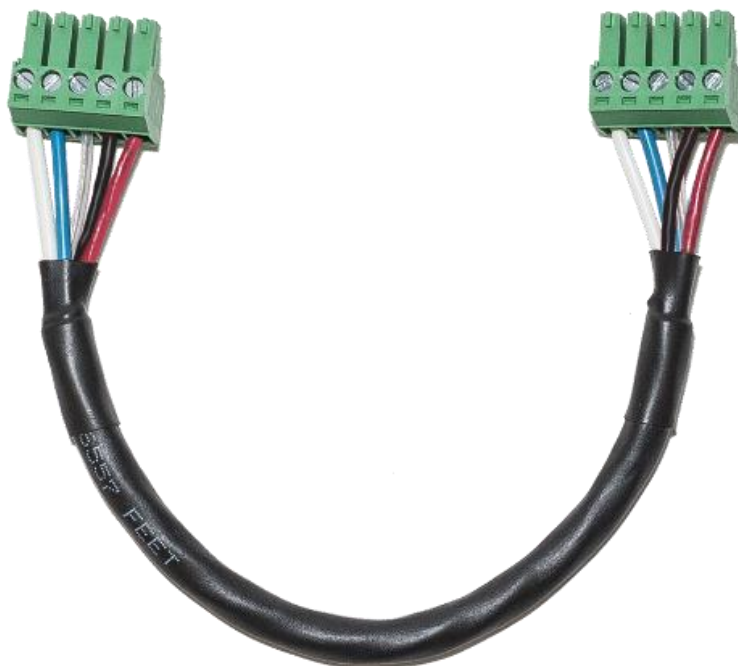

Fig. 2-34: nrgNET Pinout Connections (Integrated Controller)

2.12 Parts & Accessories

The following tables list optional and replacement items for the panel. For wire sizing and labeling, please refer to *Wire Sizing & Label Convention* (Amphenol Network Solutions Part No. 117995) included with your panel. Order parts and accessories online at amphenol-ns.com.

Steps for configuring a panel:

6. Determine the number of load connections required (one load connection per populated fuse position).
7. Select fuses:
 - Select fuse quantity equal to the number of load connections
 - Select fuse amperage values

2.12.1 Ordering Information

GMT/TPA Combination Fuse Panel:	Part Number:
240A Dual-Feed, 5/4 Panel, Vertical Inputs, Output Terminal Blocks	240GT54
240A Dual-Feed, 5/4 Panel, Horizontal Inputs, Connectorized Outputs (Connectors purchased separately)	240GT54-C
240A Dual-Feed, 5/4 Panel, Vertical Inputs, Connectorized Outputs (Tie Bar and Connectors purchased separately)	240GT54-SC
nrgSMART Circuit Monitoring, Controller, 240A Dual-Feed, 5/4 Panel, Vertical Inputs, Output Terminal Blocks	nrg240GT54-CTRL
nrgSMART Circuit Monitoring, Sensor, 240A Dual-Feed, 5/4 Panel, Vertical Inputs, Output Terminal Blocks	nrg240GT54-SENS
nrgSMART Circuit Monitoring, Controller, 240A Dual-Feed, 5/4 Panel, Horizontal Inputs, Connectorized Outputs (Connectors purchased separately)	nrg240GT54-CTRL-C
nrgSMART Circuit Monitoring, Sensor, 240A Dual-Feed, 5/4 Panel, Horizontal Inputs, Connectorized Outputs (Connectors purchased separately)	nrg240GT54-SENS-C
nrgSMART Circuit Monitoring, Controller, 240A Dual-Feed, 5/4 Panel, Vertical Inputs, Connectorized Outputs (Tie Bar and Connectors purchased separately)	nrg240GT54-CTRL-SC
nrgSMART Circuit Monitoring, Sensor, 240A Dual-Feed, 5/4 Panel, Vertical Inputs, Connectorized Outputs (Tie Bar and Connectors purchased separately)	nrg240GT54-SENS-SC
Accessories (Purchased Separately):	Part Number:
Blanking Cover: Single, Covers unused fuse holder positions	150203+03
1RU Circuit Breaker Puller	307491
4 Post Mounting Bracket Kit: 22"-36" Brackets, Mounting Hardware (requires Tie Bar, -C Versions only)	307622
Tie Bar Kit: Connectorized, Rear Mount Tie Bar, Mounting Hardware (-SC Versions only)	307661
nrgSMART Temperature Sensor, ACC, 6ft	nrgTemp

Replacement Components:	Part Number:
Replaceable Alarm Card	307608
Replaceable Alarm Card, nrgSMART	307710
Replaceable Controller Card, nrgSMART	400822
Replaceable Sensor Card, nrgSMART	307607
1RU TPA Fuse Holder	307492
Dummy GMT fuse	132748
Breaker Cover Kit: Slimline, Cover, Hardware	307689
19" Mounting Bracket Kit: 2x 19" Brackets, Mounting Hardware	PMTG19
23" Mounting Bracket Kit: 2x 23" Brackets, Mounting Hardware	PMTG23
Connectors (Purchased Separately):	Part Number:
P40 Connector Kit: TPA, 8-6 AWG, Plug, Retainer, 2x Contacts	150326
P40 Connector Kit: TPA, 12-10 AWG, Plug, Retainer, 2x Contacts	150325
P40 Replaceable Contact: TPA, 8-6 AWG, Single Contact	150333
P40 Replaceable Contact: TPA, 12-10 AWG, Single Contact	150334
P24 Connector Kit: GMT, 12-10 AWG, Plug, Retainer, 2x Contacts	150336
P24 Connector Kit: GMT, 14-12 AWG, Plug, Retainer, 2x Contacts	150342
P24 Replaceable Contact: GMT, 12-10 AWG, Single Contact	150343
P24 Replaceable Contact: GMT, 14-12 AWG, Single Contact	150344
Crimp Tool: 14-6 AWG, Daniels, M300BT	150793
Crimp Tool Locator: Universal, Daniels, UH2-5	150794
Contact Removal Tool: P40 Connector	150797

2.12.2 GMT Fuses, TPA Fuses and Circuit Breakers

GMT Fuses:	Part Number:
18/100A	130781
1/4A	100151
1/2A	004001
3/4A	004008
1A	100991
1-1/3A	004006
1-1/2A	004011
2A	004002
2-1/2A	130783
3A	004012
3-1/2A	130782
4A	004013
5A	004014
7-1/2A	004010
10A	004015
12A	102287
15A	102288
20A	127240
20A with cover	131340

240GT54/nrg240GT54

TPA Fuses:	Part Number:
5A, 170VDC	124818
10A, 170VDC	124819
15A, 170VDC	124820
20A, 170VDC	124821
25A, 170VDC	125244
30A, 170VDC	122734
40A, 170VDC	122738
50A, 170VDC	122739
Circuit Breakers:	Part Number:
5A, standard delay, UL489, without cover	149710
10A, standard delay, UL489, without cover	149711
15A, standard delay, UL489, without cover	149712
20A, standard delay, UL489, without cover	149713
25A, standard delay, UL489, without cover	149714
30A, standard delay, UL489, without cover	149715
40A, standard delay, UL489, without cover	149716
50A, standard delay, UL489, without cover	149718
60A, standard delay, UL489, without cover	149719

ⓘ ALERT

ALERT! Only use components and crimping tools approved by agencies or certifying bodies recognized in your country or region such as Underwriter's Laboratories (UL), TUV, etc.

2.12.3 Lug Reference Guide

Input Cables: 2 Hole $\frac{3}{8}$" on 1" Centers Max. Width 1.15"					
	350MCM	250MCM	4/0	3/0	2/0
T&B	—	54213	54212	54211	54210
Panduit	—	—	LCD4/0-38D-X	LCD3/0-38D-X	LCD2/0-38D-X
Burndy	YA34L2NT38FX	YA29L-2TC38	YA28L-2TC38	YA27L-2TC38	YA26L-2TC38

GMT Output Cables: 1 Hole 6-32 Max. Width .31"					
	#6	#8	#10-#12	#14-#16	#18-#22
Tyco	—	—	329697	320619	51863
Panduit	LCAN6-6-L*	LCAN8-6-L*	PN12-6HDR-D	PV14-6RNB-3K	PN18-6R-M
Burndy	YA6CLNT6*	YA8CLNT6*	—	YAE14N-43BOX	YAE18N-21BOX

*Narrow tongue lug

TPA Output Cables: 1 Hole 10-32 Max. Width .50"				
	#4	#6	#8	#10-14
T&B	54138NT*	54134	54104	—
Panduit	LCAN4-10-L*	LCA6-10-L	LCA8-10-L	LCA10-10-L
Burndy	YA4CL1-BOX	YA6CL1-BOX	YA8CL-BOX	YAV10-BOX

*Narrow tongue lug

Ground Cables: 2 Hole $\frac{1}{4}$" on $\frac{5}{8}$" Centers			
	#1	#2	#4
T&B	54208	54207	54206
Panduit	LCD1-14A-E	LCD2-14A-Q	LCD4-14A-L
Burndy	YA1CL-2TC14	YA2CL-2TC14	YA4CL-2TC14

Section Three: Drawings

3.1 240GT54 Drawings

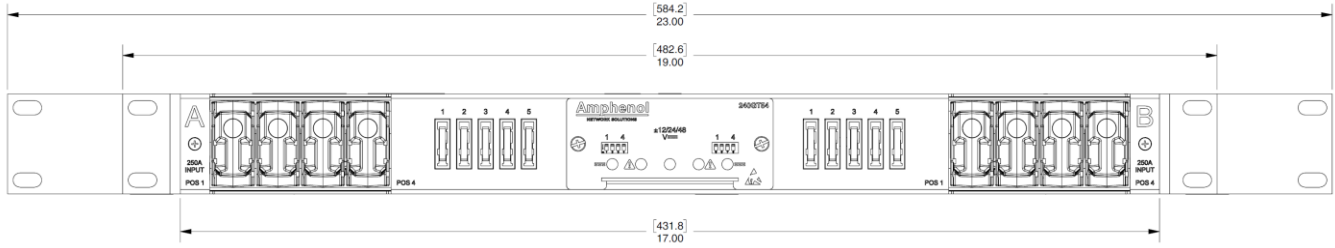

Fig. 3-1: Front View (Passive Versions)

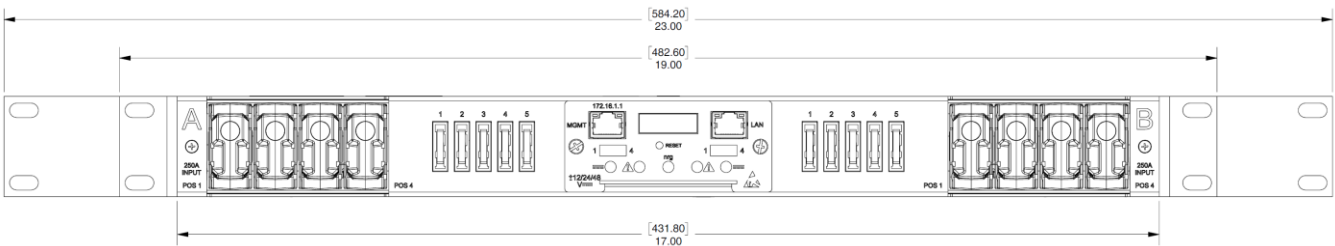

Fig. 3-2: Front View (nrgSMART -CTRL Versions)

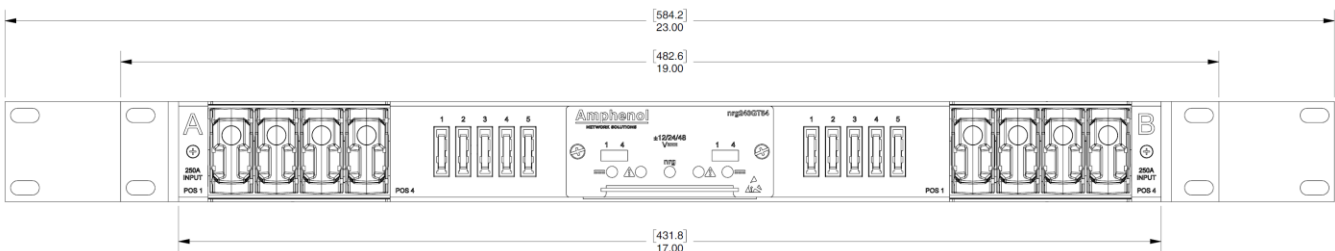

Fig. 3-3: Front View (nrgSMART -SENS Versions)



Fig. 3-4: Side View (Standard and -SC Versions)

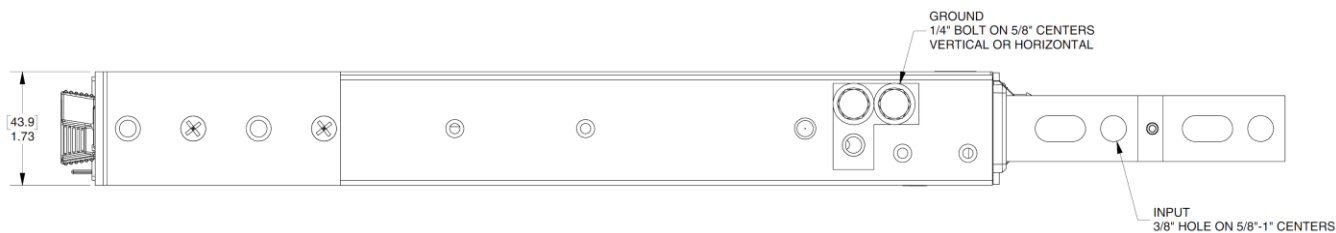

Fig. 3-5: Side View (-C Versions)

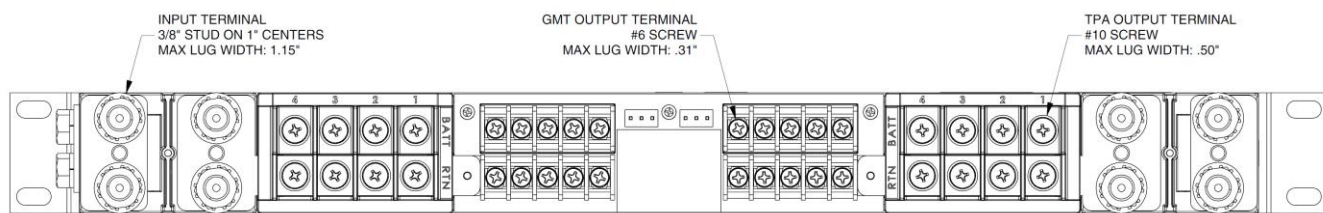

Fig. 3-6: Rear View (240GT54)

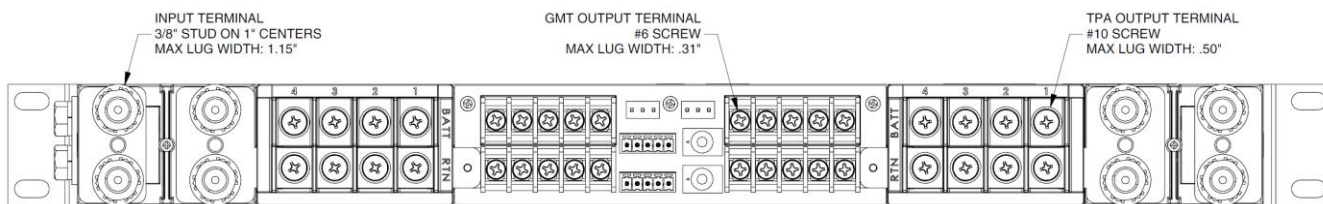

Fig. 3-7: Rear View (nrg240GT54-CTRL and nrg240GT54-SENS)

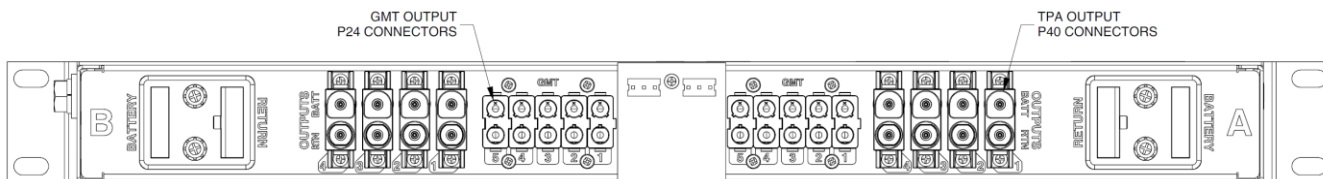

Fig. 3-8: Rear View (240GT54-C)

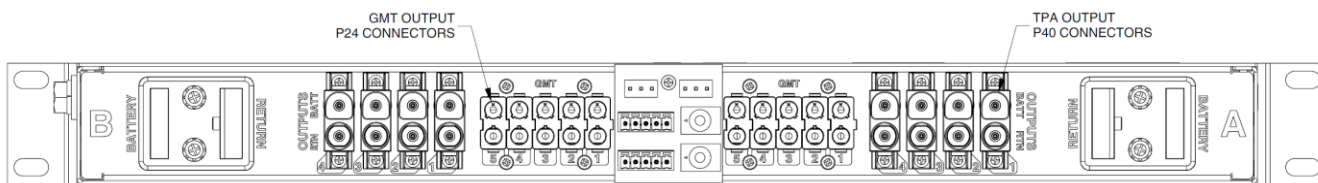

Fig. 3-9: Rear View (nrg240GT54-CTRL-C and nrg240GT54-SENS-C)

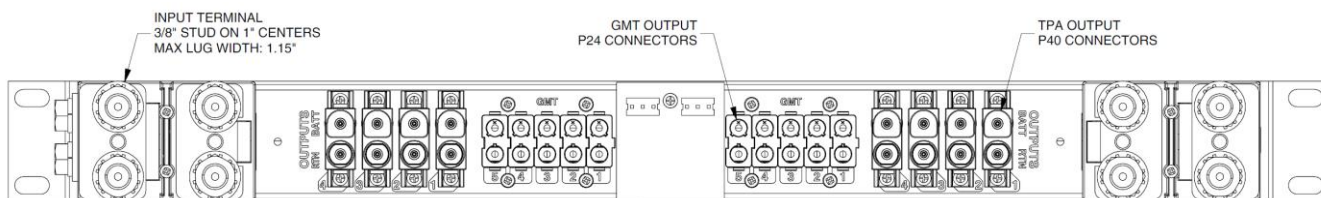

Fig. 3-10: Rear View (240GT54-SC)

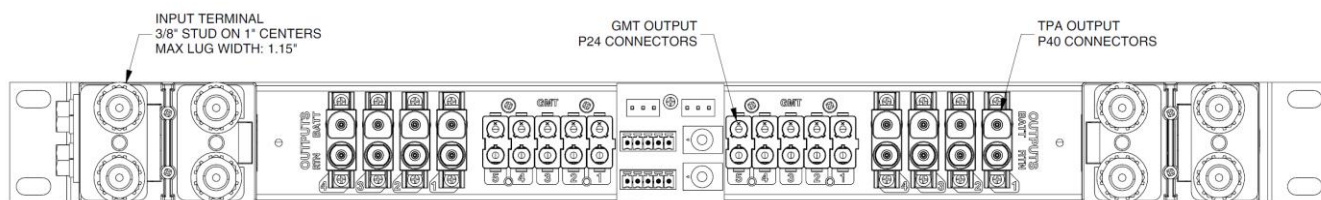

Fig. 3-11: Rear View (nrg240GT54-CTRL-SC and nrg240GT54-SENS-SC)

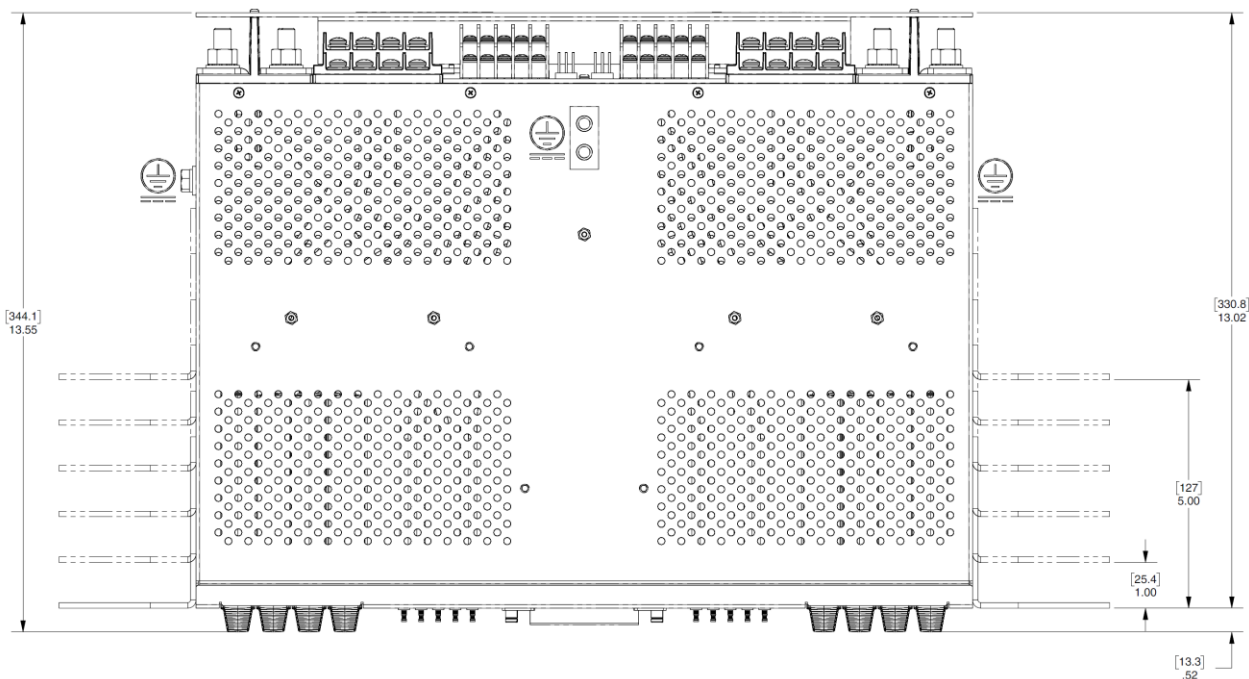

Fig. 3-12: Bottom View (Standard Versions)

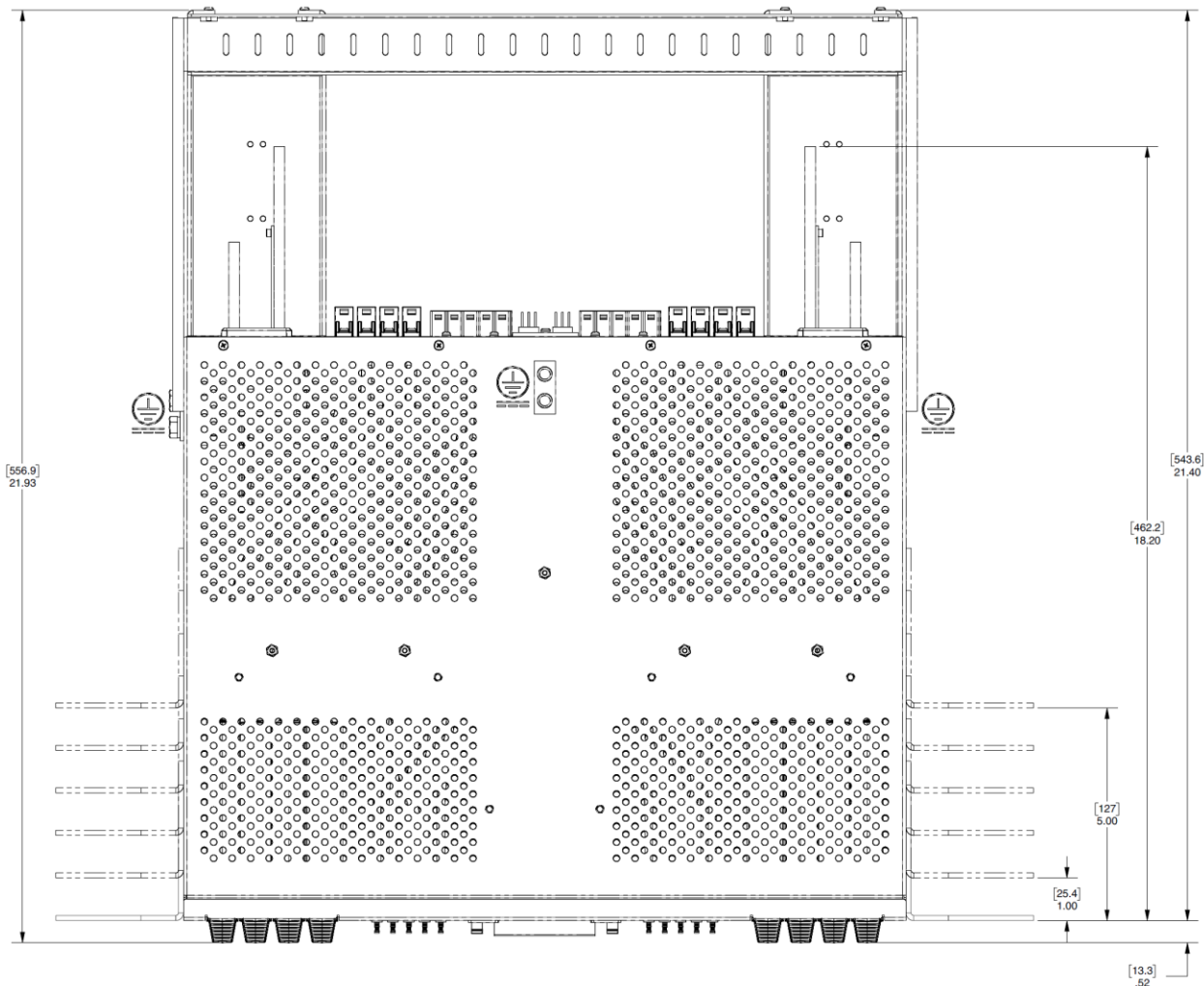

Fig. 3-13: Bottom View (-C Versions)

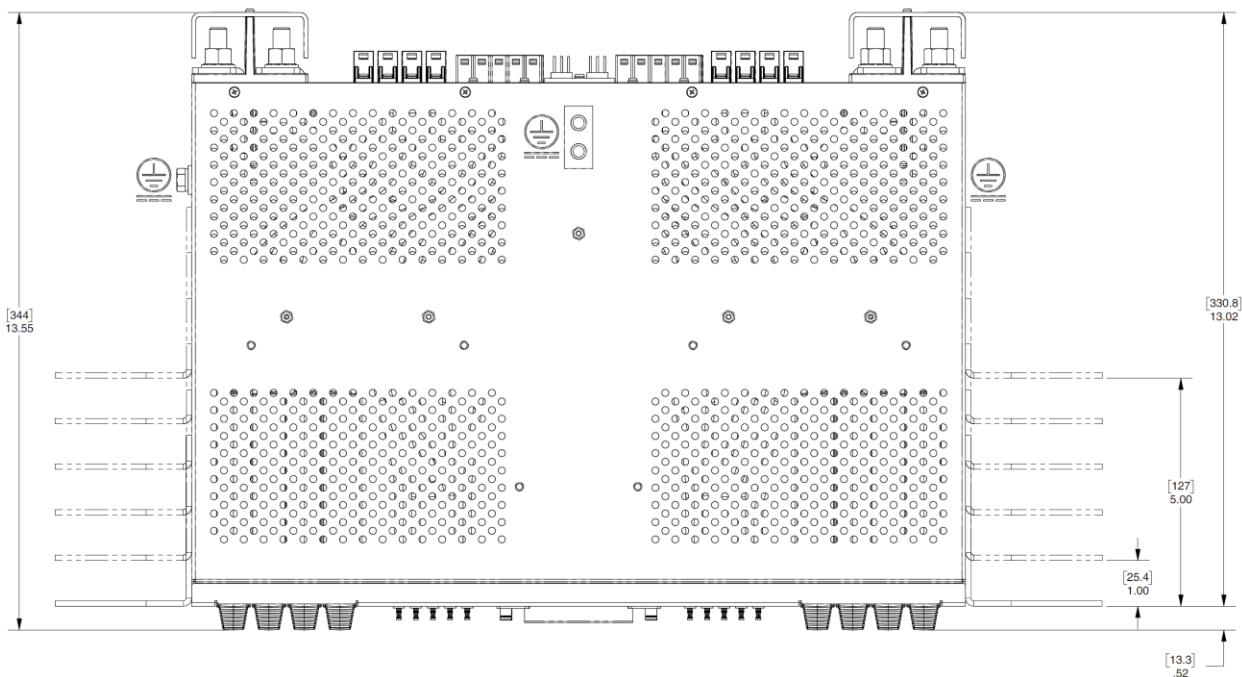

Fig. 3-14: Bottom View (-SC Versions)

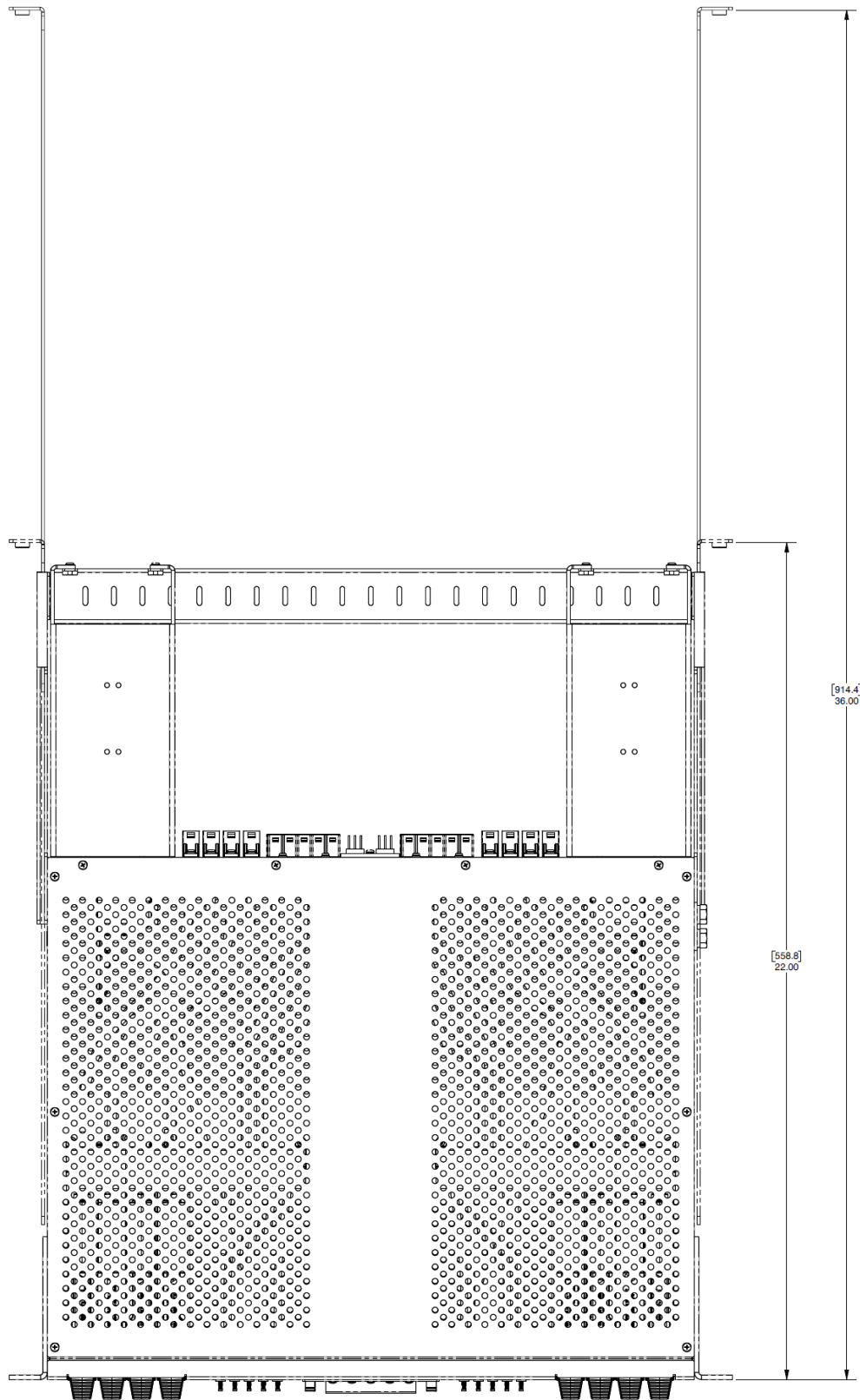

Fig. 3-15: Optional 4 Post Mounting Bracket (-C Versions)

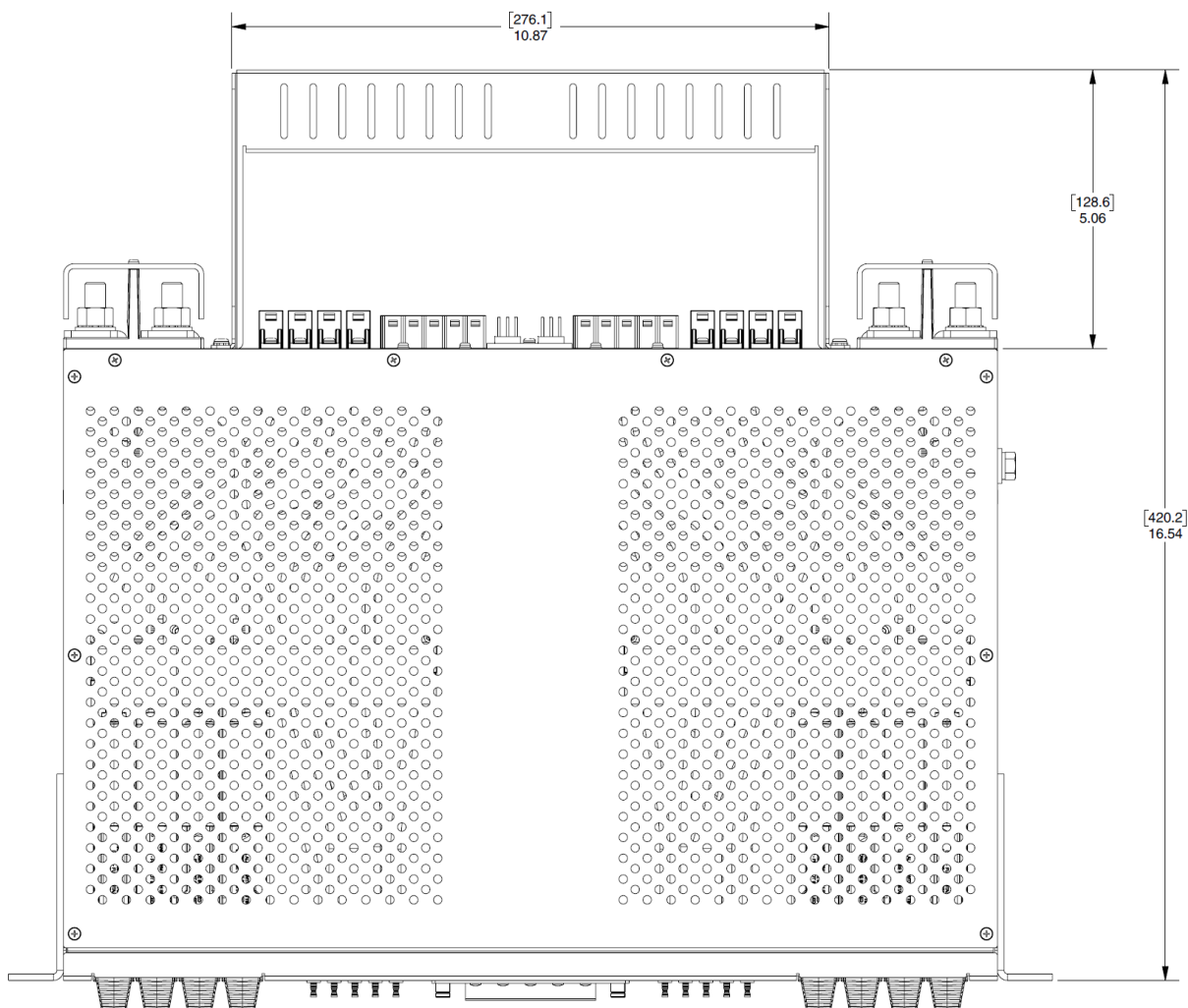

Fig. 3-16: Optional Tie Bar (-SC Versions)

Section Four: Notices (nrgSMART Versions)

4.1 FCC Class A Notice

This device complies with part 15 of the FCC Rules. Operation is subject to the following two conditions:

1. This device may not cause harmful interference
2. This device must accept any interference received, including interference that may cause undesired operation.

NOTE: This equipment has been tested and found to comply with limits for Class A digital device, pursuant to part 15 of the FCC Rules. These limits are designed to provide a reasonable protection against harmful interference when the equipment is operated in a commercial environment. This equipment generates, uses and can radiate radio frequency energy and, if not installed and used in accordance with the instruction manual, may cause harmful interference to radio communications. Operation of this equipment in a residential area is likely to cause harmful interference in which case the user will be required to correct the interference at his own expense.

Modification

Any modifications made to this device that are not approved by Amphenol Network Solutions may void the authority granted to the user by the FCC to operate this equipment.

4.2 ICES-003 Class A Notice – Avis NMB-003, Class A

This Class A digital apparatus complies with Canadian ICES-003.

Cet appareil numérique de la classe A est conforme à la norme NMB-003 du Canada.



ELECTROSTATIC DISCHARGE (ESD) PRECAUTIONS

ELECTROSTATIC DISCHARGE (ESD) PRECAUTIONS! When handling any electronic component or assembly you must observe the following antistatic precautions to prevent damage. Always disconnect power from the server and wear a grounded wrist strap when working around the Controller. Always wear a grounded wrist strap when handling printed circuit boards. Treat all assemblies, components and interface connections as static-sensitive.